

# Superconducting Wiggler Magnets and Cryogenic Systems Upgrades For The NSLS X-Ray Ring

Payman Mortazavi

Brookhaven National Laboratory, P.O. Box 5000 – 725C, Upton., NY 11973-5000 - U.S.A.

Phone: (631) 344 – 4743 - Fax: (631) 344 – 3029

E-mail: Payman@bnl.gov

## Abstract

A 6 pole, 6 Tesla superconducting wiggler magnet provides collimated, high intensity, high energy x-rays to the X-17 straight section of the x-ray ring at the National Synchrotron Light Source (NSLS). A semi-automated, closed-loop cryogenic cycle maintains this magnet at 4.2 °K continuously for nearly ten months each year. Oxford Instruments, UK have built a new 13 pole superconducting wiggler magnet with significantly better thermal efficiency able to operate with three different modes that is intended to replace the existing wiggler unit. These two wigglers have two distinctly different cryogenic systems. A brief review of their design features and their cryogenic systems are described.

## 1. Introduction

The National Synchrotron Light Source (NSLS) at the Brookhaven National Laboratory (BNL) is a second generation electron accelerator facility consisting of a 70 MeV Linear Accelerator, a 750 MeV Booster Injector combination, a 750 MeV, 1 A Ultra Violet (UV) storage ring, and a 2.8 GeV, 300 mA X-ray storage ring. In addition to bending magnet radiation, there are nine insertion devices, eight normal conducting undulators (7)/ wiggler (1), and one superconducting wiggler magnet. The latter, the X17 Superconducting Wiggler, was designed and built at NSLS in the mid-1980s. Oxford Instruments, Ltd. recently built a new superconducting wiggler. Both of them can provide experimenters with high intensity, high energy x-rays.

The present X17 superconducting wiggler uses a 5 full and 2 half pole magnet array and can operate up to 6 Tesla. This device (figure 1) was built in-house and has been operating since 1989. It is the source of high energy x-rays to four NSLS beamlines (X17B1, B2, B3, and X17C) that support programs in material science, high pressure research, and biomedical studies (including digital-subtraction angiography). However, this X17 wiggler and its associated electronics and cryogenics-systems (described later) have aged, and must be replaced with a new state-of-the-art wiggler.

Due to deficiencies that appear with aging, and to better meet the projected needs for research, a contract was awarded in late 1995 to the Oxford Instruments company to design and manufacture a completely new wiggler, with superior features. The Oxford wiggler was designed to have three different modes of operation (see figure 2): the full wiggler with eleven poles producing 3.0 T, the partial wiggler with five poles at 4.7 T, and the wavelength shifter with a single pole producing 5.5 T.

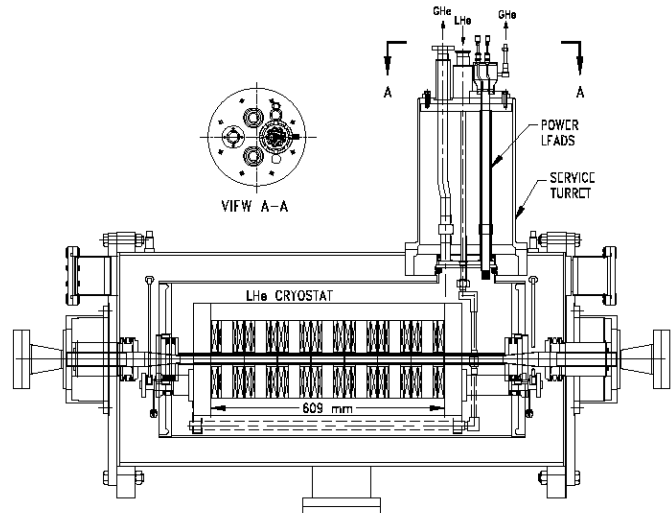
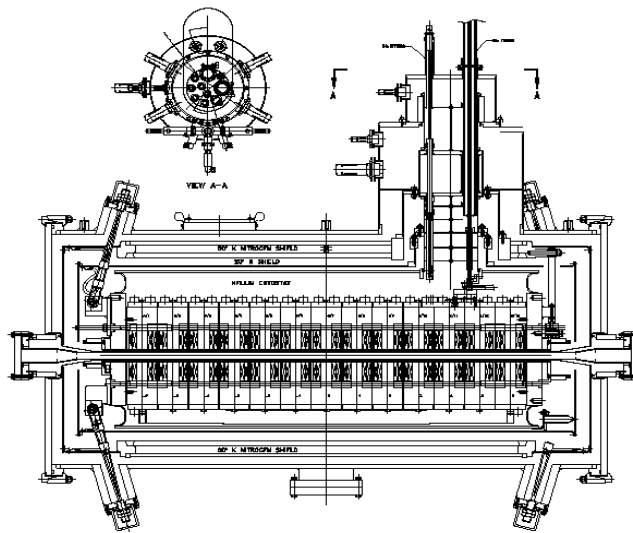

FIG.1: EXISTING, 6 POLES 6 TESLA S.C.W.

To maintain consistent beam dynamics in the X-ray storage ring, the specifications were that the Oxford wiggler should provide similar flux to the existing X-17 wiggler. Accordingly, a partial wiggler mode was incorporated to deliver the same flux as the existing wiggler for solid-state physics experiments, while the full wiggler and wavelength shifter modes will produce x-rays for different types of experiments that cannot be undertaken with the existing one. The mechanical design and its associated cryogenics was simplified, and equipped with improved instrumentation (described later). A series of manufacturing setbacks delayed the completion and delivery of this wiggler until March 2004. It will replace the current unit after successfully completing tests now underway at BNL.



## 2. Mechanical Design

While the mechanical designs of these wigglers are quite different, there are some similarities, including the following ones:

- Both wigglers poles are constructed from similar low-carbon steel to minimize residual magnetization.
- Both wigglers coils are made from Nb-Ti superconductor material. The coils around each pole consist of inner and outer layers to better match the critical current limits of the superconductors.
- Both wigglers have a warm insulated bore, but use different methods to keep it warm. The existing wiggler's bore tube is shielded from the cryostat temperature by an insulated vacuum and super insulation, while the new one has additional heaters to maintain the beam's tube above 0°C to prevent water vapor freezing should there be a vacuum leak in the storage ring.
- The poles and superconducting magnet coils of both wigglers are mounted in a 4.2 °K liquid helium bath. Heat transfer in the existing wiggler is reduced by a shield consisting of super insulation and a vacuum, while the new wiggler also incorporates two additional heat shields; from a 20 °K shield cooled by boil-off helium vapor, and from a 77 °K liquid-nitrogen reservoir. These profound differences have a significant impact on cryogenic consumption, as discussed later.

## 3. Instrumentation

The existing wiggler's interlocks are set to the pre-determined minimum-acceptable liquid level within the magnet cryostat. Interlocks also are set to instruments that sense internal cryostat pressure; loss of insulating vacuum, and current leads' temperatures. However, the existing wiggler does not have adequate numbers of temperature sensors to help insure proper cool down- or warm-up-rates, or aid during troubleshooting. The Oxford wiggler, on the other hand, is equipped with multiple, redundant temperature/level and pressure sensors to aid with cool down/warm-up rates for operational- and troubleshooting-purposes.

## 4. Cryogenics

The existing wiggler's cryogenic system uses a semi-automated closed-loop helium cycle consisting of a CTI 1430 Refrigerator/Liquefier, two alternately-used RS Screw Compressors, an external LN<sub>2</sub> cooled purifier, a 1,000 liter LHe Dewar, Make-up/Recovery Gaseous helium tanks, associated transfer lines, and several sets of digital controllers (figure 3). The entire wetted helium masses are pre-cooled through re-circulating pre-cooled 110 psi gaseous helium using the external purifier's LN<sub>2</sub> bath. In this way, the temperatures of the cold masses approach approximately 90 °K in 24 hours cool-down time. The liquefier then is put into full liquefying mode until about 800 liters of liquid helium have accumulated in the buffer dewar. The magnet is then filled with liquid helium and the system is returned to its steady-state operational mode. The excess liquid helium produced is boiled off by heaters attached to the inner vessel and controlled externally by a variable power transformer. A series of pressure/liquid level and temperature sensors provide signals for automation, alarm, interlock, and display. The magnets are ramped up to the desired field (3 or 4.2 T routinely) at a predetermined ramp rate (~1.14 T/min) after the x-ray ring has been filled with electrons and the beam energy ramped up from 750 MeV to 2.8 GeV. The reverse sequence is followed during ramp-down and warm-up periods.

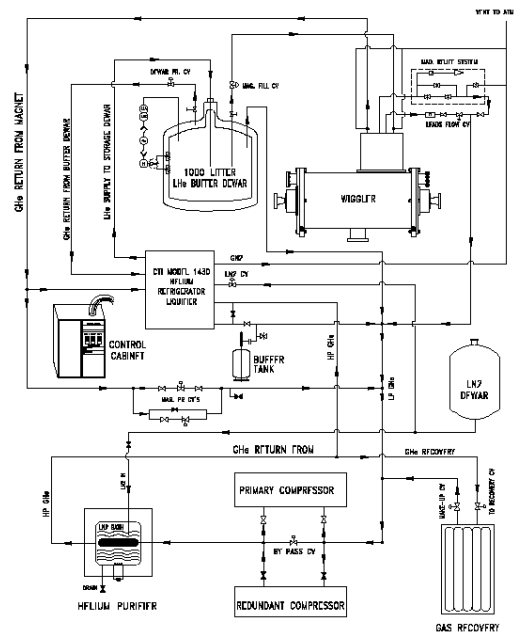

FIG. 3: EXISTING WIGGLER CRYOGENIC SYSTEM

The present X-17 wiggle cryostat suffers high heat losses due to poorly designed heat shields, inefficient power leads, relatively long transfer lines, and associated bayonets/control valves. The combined thermal loads together require ~ 20 liters of liquid helium to maintain steady-state operation; this is about 80% of the cryogenic system's peak capability. The reserve capacity of LHe tends to fall below steady-state requirements in about eight weeks. Every two days the liquefier's cold box is routinely refurbished (while cryogenically disconnected from rest of system) to minimizing the chance of unscheduled down-time. These cumulative inefficiencies, along with high maintenance and operating costs, were the main reason for acquiring a new wiggler with superior reliability and functionality.

The new Oxford wiggler has open loop helium and nitrogen systems (figure 4). Total heat loads are limited to between less than 1 to 2 watts depending on best-case conditions (superior heat shields and helium transfer mechanism) or worst-case ones (failure of the leads of the High Temperature Superconducting coil when the wiggler is operating in either partial- or wave shifter-modes).

There are several plans for establishing cryogenic configurations to operate this wiggler when it installed in the x-ray ring. The final selection will depend on the findings from tests soon to be conducted at BNL. The optimum goal is to change the helium open-loop cycle to a closed-loop type by re-condensing boil-off helium vapor with cryo-coolers and a low-loss cryostat. The efficacy of this design will depend on helium vapor's quality factor, and the capabilities of the available cryo-cooler.

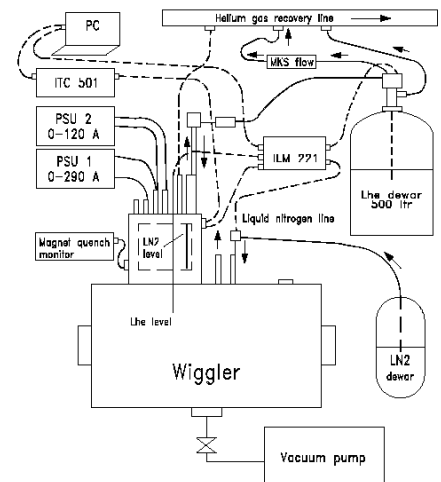

FIG. 4: NEW WIGGLER, CRYOGENIC SYSTEM

## **5. Conclusion:**

Presently, there are two distinctly different superconducting wigglers at NSLS facility, one in operation since 1989, and the other in its testing stages. Both wigglers were designed to provide four NSLS beamlines with collimated, high intensity and high energy x-rays. While both are similar magnetically in their full operational modes, they differ significantly in several aspects of their mechanical and cryogenic design. The large amount and the high cost of required labor to support operations, combined with the expenses of high operational power and the replacement of components in the existing wiggler led to the decision to pursue superseding it with a more efficiently-designed one. Oxford Instruments of UK has manufactured and delivered a new wiggler with heat load no more than 0.5 watts (static) compared to 7 watts for the existing wiggler. It should supplant the current wiggler after successfully completing all operational and endurance tests at BNL.

## **6. Acknowledgements:**

The author thanks Ed Haas and Yoong Koh for their assistance with editing and preparing the graphics. Support was provided by the U.S. Department of Energy under contract No. DE-AC02-98CH10886.

## **7. References**

1. S. Krinsky, W. Thomilson, and A. Vansteenbergen, "An Overview of Undulators and Wigglers for the NSLS", BNL Report No 31989, September 1982
2. H. Hsieh, S. Krinsky, A. Luccio, C. Pellegrini, and A. Vansteenbergen, "Wiggler, Undulator and Free Electron Laser Radiation Sources Development at the National Synchrotron Light Source", Nuclear Instruments and Methods, 1983.
3. H. Hsieh, S. Krinsky, A. Luccio, and A. Vansteenbergen, "Design of A 6 Tesla Wiggler for the National Synchrotron Light Source", IEEE Transactions on Nuclear Science vol.ns-28, no.3, pt.2 : 3292-4, June 1981.
4. E.B. Blum, D. R. Lynch, P. Mortazavi, O.V. Singh, W. Thomilson, and M.H. Woodle, " A Superconducting Wiggler Magnet For The NSLS X-Ray Ring", PAC Proc. 1997 Part. Acc. Conf, Vol 3 pp, 3494-3496.